

PARTS LIST				
ITEM	QTY	PART NUMBER	MATERIAL	DESCRIPTION
1	1	BASE	CAST, IRON	
2	1	SLIDING JAW	CAST, IRON	
3	2	JAW PLATE	SAE 3140	
4	1	VISE SCREW	SAE 3140	
5	1	COLLAR	SAE 1020	
6	1	SPECIAL KEY	SAE 1020	
7	1	HANDLE ROD	COLD ROLLED, STEEL	
8	2	HANDLE BALL	SAE 1020	
9	2	SLIDE KEY	SAE1020	
10	2	SET SCREW	SAE 1016	
11	4	SLOTTED FLAT COUNTERSUNK HEAD MACHINE SCREW	STEEL, MILD	ANSI B18.6.3-10-24X 5/8
12	2	TAPER PIN	STANDARD	#000 TAPER PIN

MACHINE VISE MASTER ASSEMBLY  
SCALE 1 : 1

**LEGEND:**

∅	DIAMETER
R	RADIUS
°	DEGRES
⊔	COUNTERBORE
∇	DEPTH
∨	COUNTERSINK

**GENERAL NOTES:**

FILLEDS AND ROUNDS R.125 UNLESS OTHERWISE NOTED



DIGITAL DESIGN  
GRAPHICS  
TECHNOLOGY

WWW.DDGT.NET

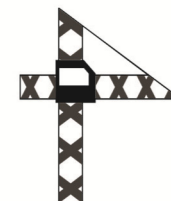

**Fernando Morales**

- Landscape Design
- Retaining Walls
- Decks
- Water Features
- Outdoor Lighting
- Irrigation System
- Top Soil
- Plants, Trees, & Turf
- Stamp Concrete

(707) 304-3362

morales15fernando@gmail.com

www.ddgt.net/StudentPages/fmorales

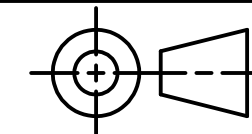

TOLERANCES UNLESS SPECIFIED:  
DECIMAL INCHES:  
X = ±.020  
XX = ±.010  
XXX = ±.005  
FRACTIONAL ±1/64"  
ANGLES ±1 DEGREE

SURFACES 32 ✓

COURSE: DDGT240

INVENTOR DRAWING NAME:  
MACHINE VISE

FIG #: 14-17

DRAFTER: F. MORALES

DATE: 10/9/2018

SCALE: AS NOTED

PAGE #: 1 OF 5

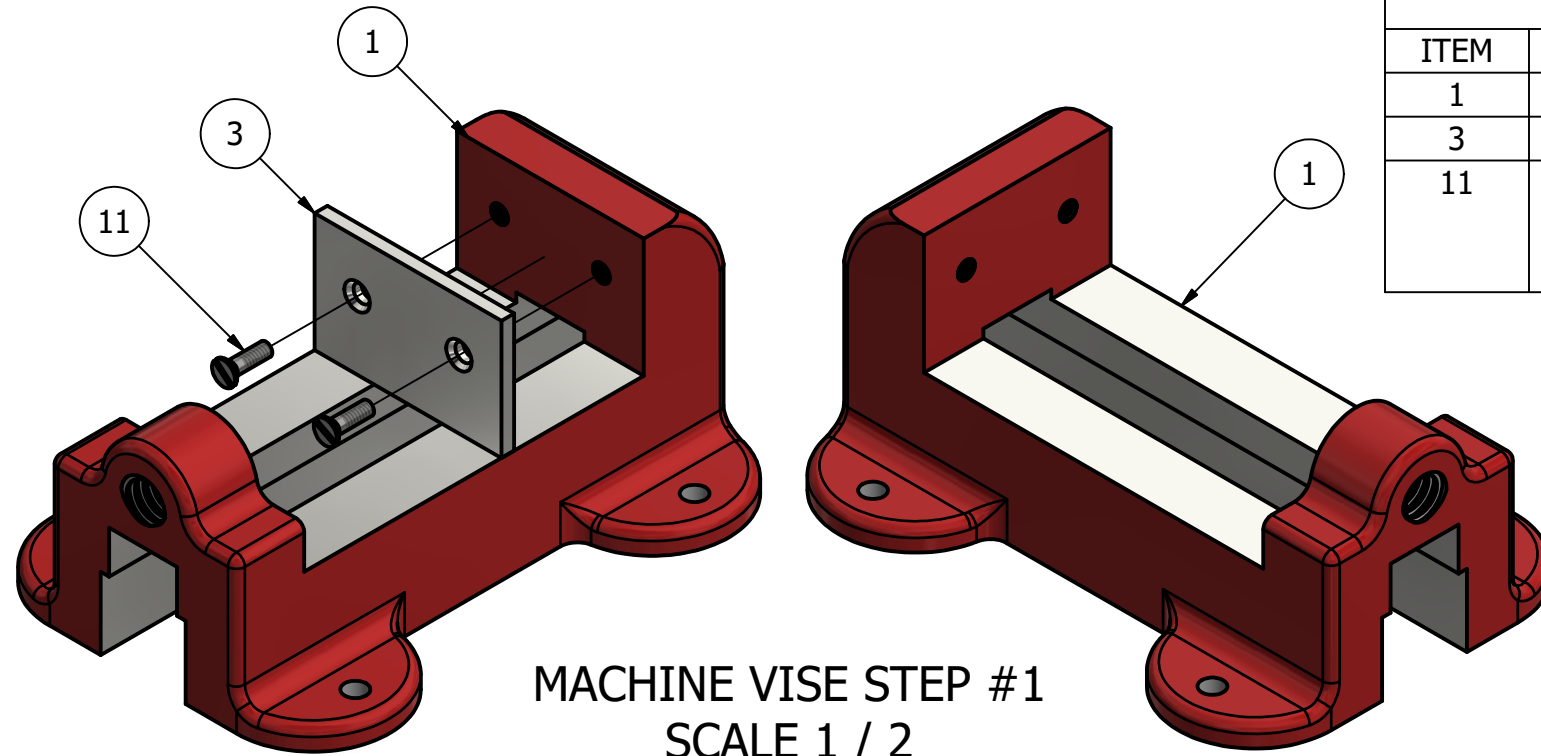
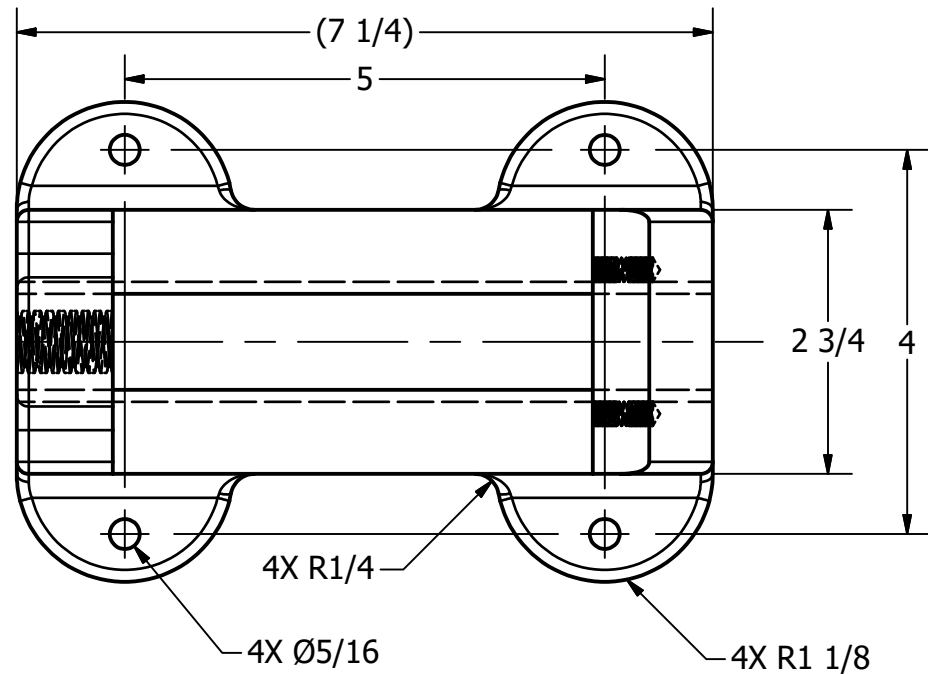

PARTS LIST		
ITEM	QTY	PART NUMBER
1	1	BASE
3	2	JAW PLATE
11	4	SLOTTED FLAT COUNTERSUNK HEAD MACHINE SCREW

MACHINE VISE STEP #1  
SCALE 1 / 2

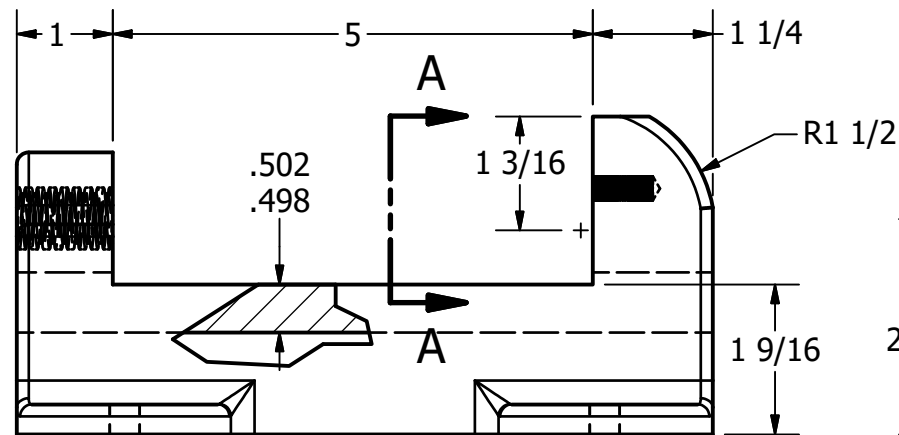

BASE  
SCALE 1 / 2

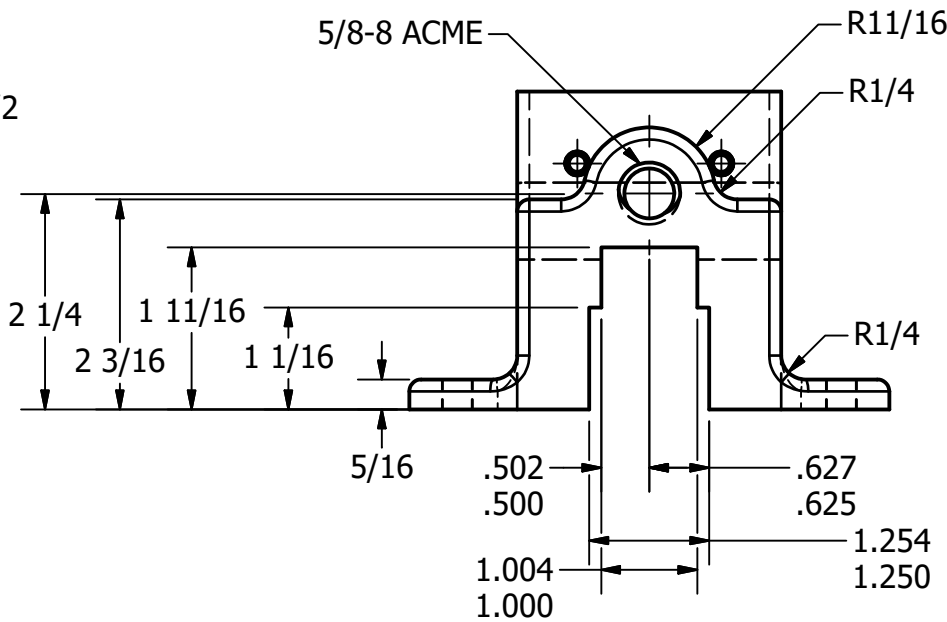

2X DRILL √ FOR  
1/4 FL HD MACH SCR

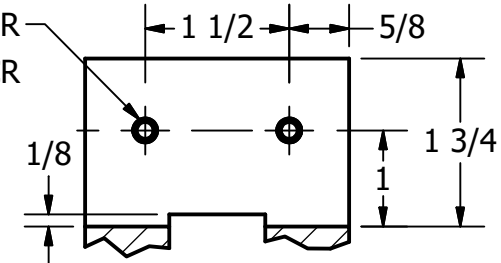

SECTION A-A  
SCALE 1 / 2

**LEGEND:**

- Ø DIAMETER
- R RADIUS
- ° DEGRES
- COUNTERBORE
- ∇ DEPTH
- √ COUNTERSINK

**GENERAL NOTES:**

FILLEDS AND ROUNDS R.125 UNLESS OTHERWISE NOTED



DIGITAL DESIGN  
GRAPHICS  
TECHNOLOGY

WWW.DDGT.NET

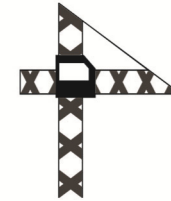

**Fernando Morales**

- Landscape Design
- Retaining Walls
- Decks
- Water Features
- Outdoor Lighting
- Irrigation System
- Top Soil
- Plants, Trees, & Turf
- Stamp Concrete

(707) 304-3362

morales15fernando@gmail.com  
www.ddgt.net/StudentPages/fmorales

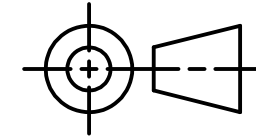

TOLERANCES UNLESS SPECIFIED:  
DECIMAL INCHES:  
X = ±.020  
XX = ±.010  
XXX = ±.005  
FRACTIONAL ±1/64"  
ANGLES ±1 DEGREE  
SURFACES 32 ✓

COURSE: DDGT240

INVENTOR DRAWING NAME:  
MACHINE VISE

FIG #: 14-17

DRAFTER: F. MORALES

DATE: 10/9/2018

SCALE: AS NOTED

PAGE #: 2 OF 5

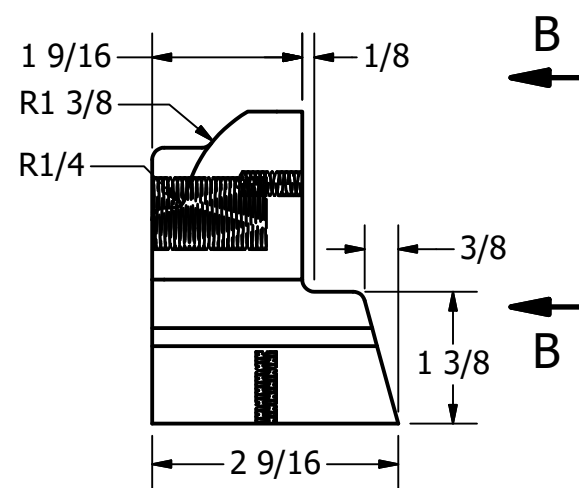
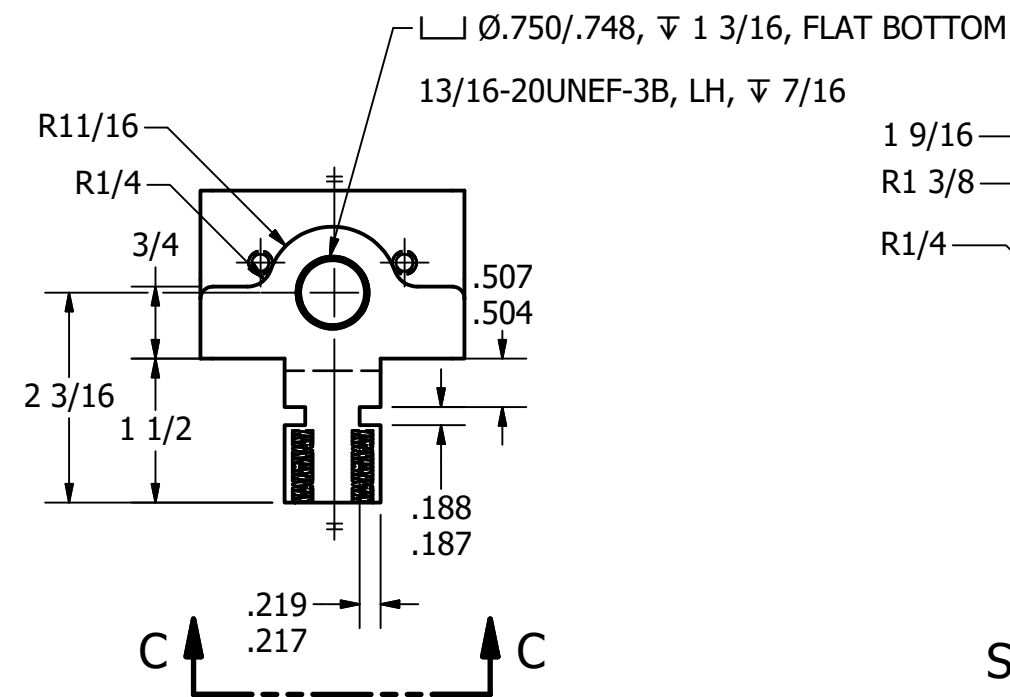

SLIDING JAW  
SCALE 1 / 2

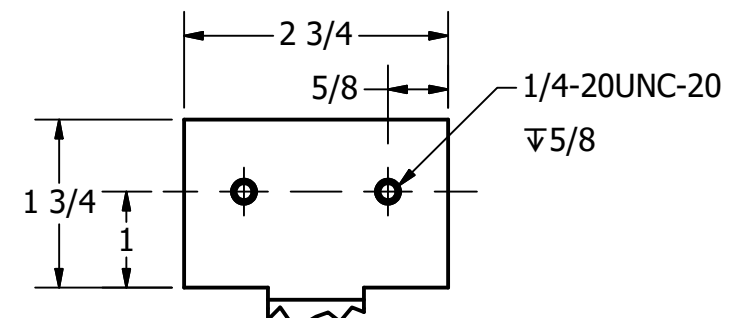

VIEW B-B  
SCALE 1 / 2

PARTS LIST		
ITEM	QTY	PART NUMBER
2	1	SLIDING JAW
3	2	JAW PLATE
11	4	SLOTTED FLAT COUNTERSUNK HEAD MACHINE SCREW

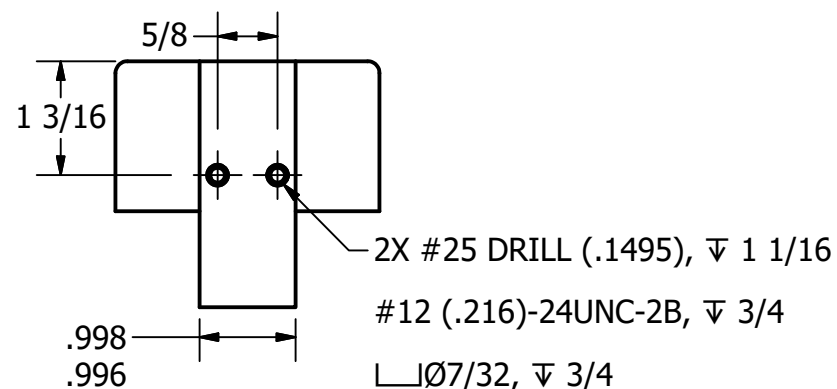

VIEW C-C  
SCALE 1 / 2

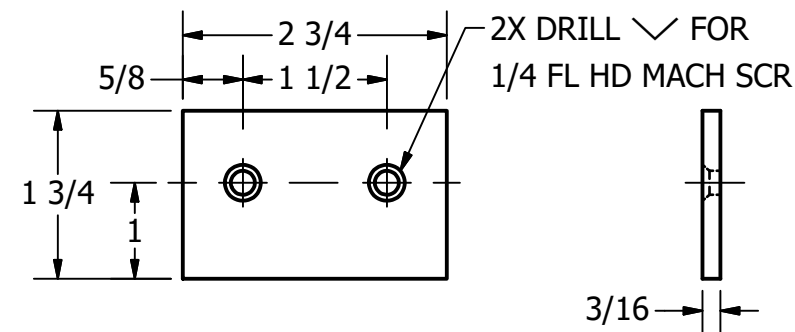

JAW PLATE  
SCALE 1 / 2

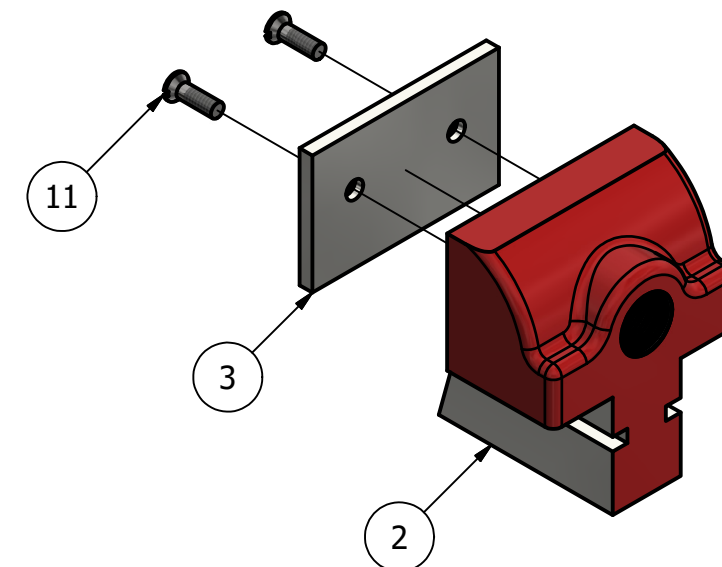

MACHINE VISE STEP #2  
SCALE 1 / 2

**GENERAL NOTES:**

FILLEDS AND ROUNDS R.125 UNLESS OTHERWISE NOTED

**LEGEND:**

- $\varnothing$  DIAMETER
- R RADIUS
- ° DEGRES
- $\sqcup$  COUNTERBORE
- $\nabla$  DEPTH
- $\sphericalangle$  COUNTERSINK



DIGITAL DESIGN  
GRAPHICS  
TECHNOLOGY

WWW.DDGT.NET

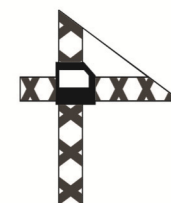

**Fernando Morales**

- Landscape Design
- Retaining Walls
- Decks
- Water Features
- Outdoor Lighting
- Irrigation System
- Top Soil
- Plants, Trees, & Turf
- Stamp Concrete

(707) 304-3362

morales15fernando@gmail.com  
www.ddgt.net/StudentPages/fmorales

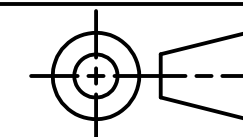

TOLERANCES UNLESS SPECIFIED:  
DECIMAL INCHES:  
X =  $\pm$ .020  
XX =  $\pm$ .010  
XXX =  $\pm$ .005  
FRACTIONAL  $\pm$ 1/64"  
ANGLES  $\pm$ 1 DEGREE

SURFACES  $\sphericalangle$

COURSE: DDGT240

INVENTOR DRAWING NAME:  
MACHINE VISE

FIG #: 14-17

DRAFTER: F. MORALES

DATE: 10/9/2018

SCALE: AS NOTED

PAGE #: 3 OF 5

PARTS LIST		
ITEM	QTY	PART NUMBER
4	1	WISE SCREW
7	1	HANDLE ROD
8	2	HANDLE BALL
12	2	TAPER PIN

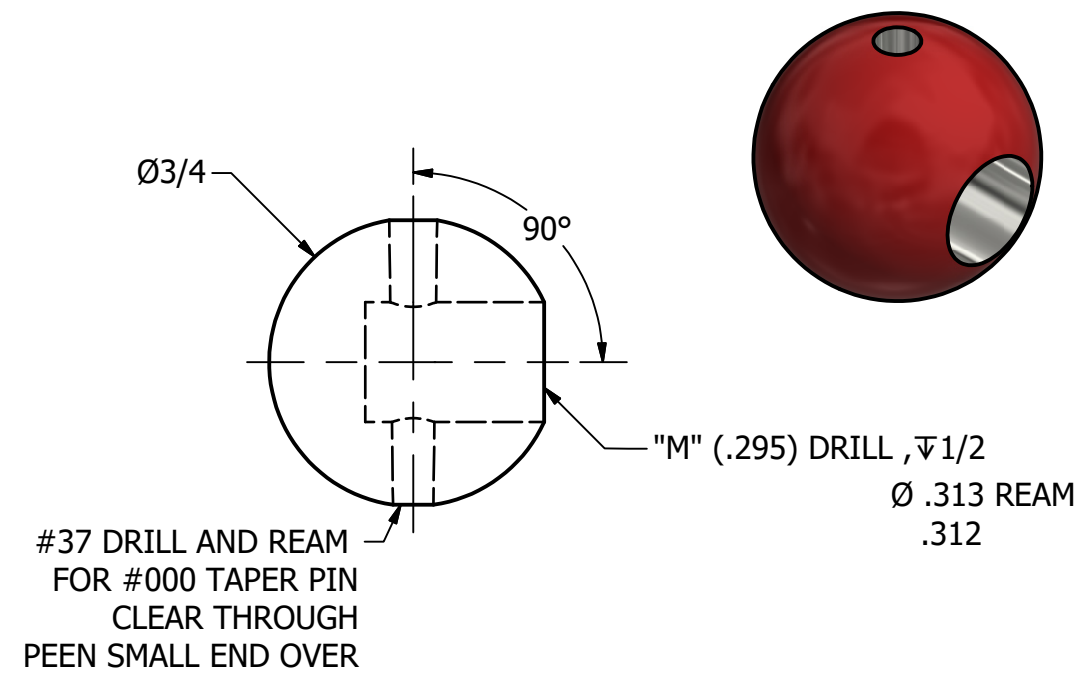

**HANDLE BALL**  
SCALE 2 : 1

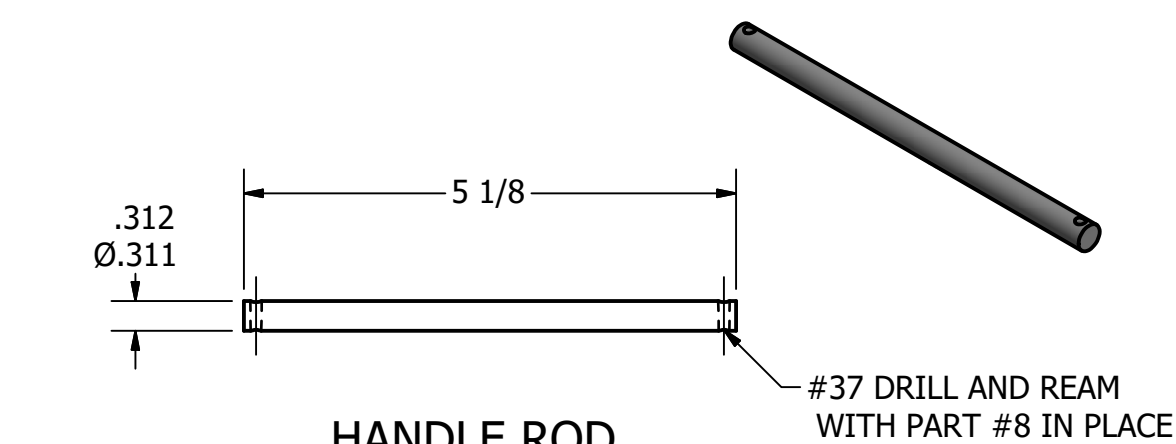

**HANDLE ROD**  
SCALE 1 / 2

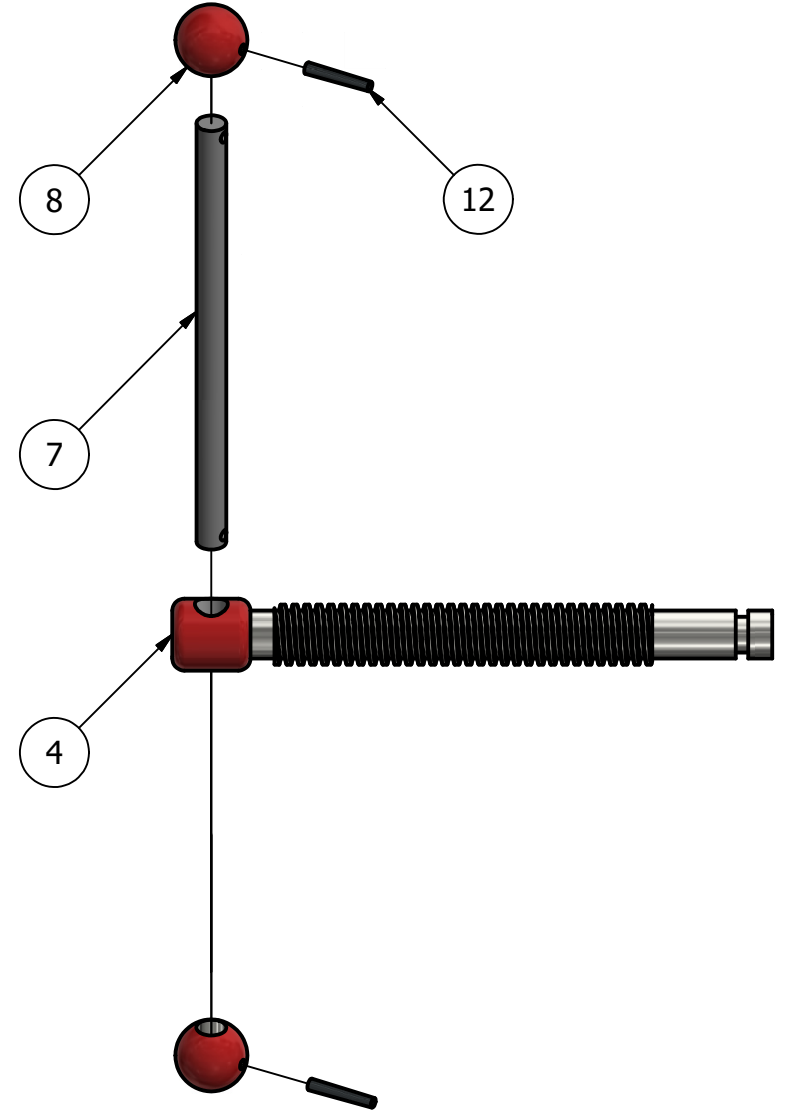

**MACHINE VISE STEP #3**  
SCALE 1 / 2

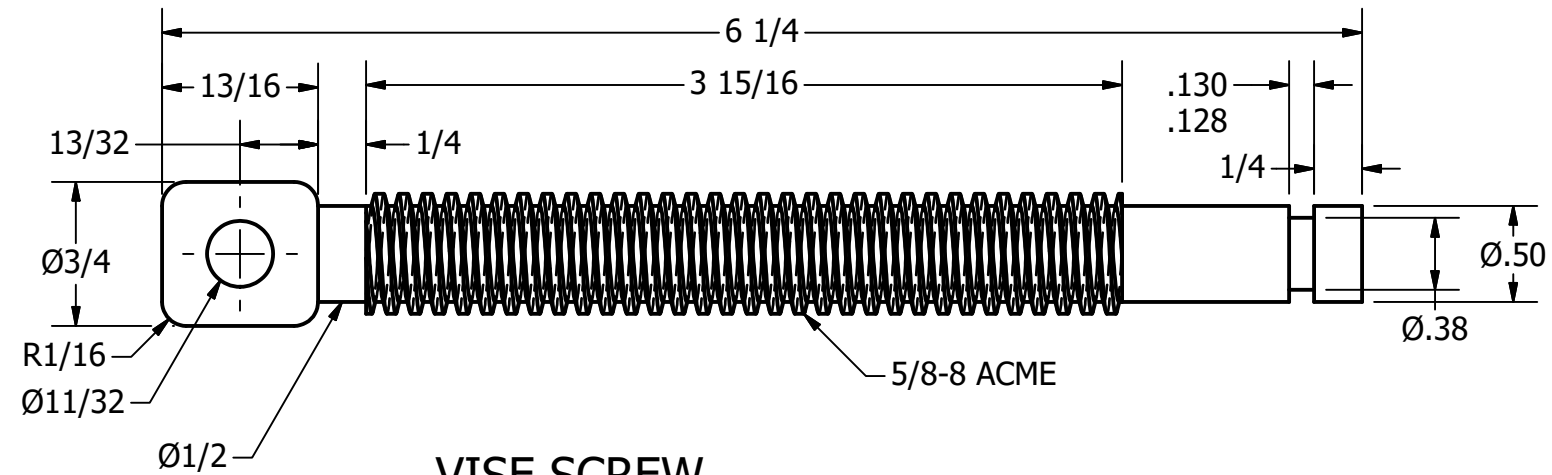

**WISE SCREW**  
SCALE 1 : 1

**LEGEND:**  
 Ø DIAMETER  
 R RADIUS  
 ° DEGREES  
 □ COUNTERBOR  
 ▽ DEPTH  
 ✓ COUNTERSINK

**GENERAL NOTES:**  
 FILLEDS AND ROUNDS R.125 UNLESS OTHERWISE NOTED

**DDGT**  
 DIGITAL DESIGN  
 GRAPHICS  
 TECHNOLOGY  
 WWW.DDGT.NET

**Fernando Morales**  
 -Landscape Design -Irrigation System  
 -Retaining Walls -Top Soil  
 -Decks -Plants, Trees, &  
 -Water Features Turf  
 -Outdoor Lighting -Stamp Concrete  
 (707) 304-3362  
 morales15fernando@gmail.com  
 www.ddgt.net/StudentPages/fmorales

TOLERANCES UNLESS SPECIFIED:  
 DECIMAL INCHES:  
 X = ±.020  
 XX = ±.010  
 XXX = ±.005  
 FRACTIONAL ±1/64"  
 ANGLES ±1 DEGREE  
 SURFACES 32 ✓

COURSE:	DDGT240
INVENTOR DRAWING NAME:	MACHINE VISE
FIG #:	14-17
DRAFTER:	F. MORALES
DATE:	10/9/2018
SCALE:	AS NOTED
PAGE #:	4 OF 5



PARTS LIST		
ITEM	QTY	PART NUMBER
5	1	COLLAR
6	1	SPECIAL KEY
9	2	SLIDE KEY
10	2	SET SCREW

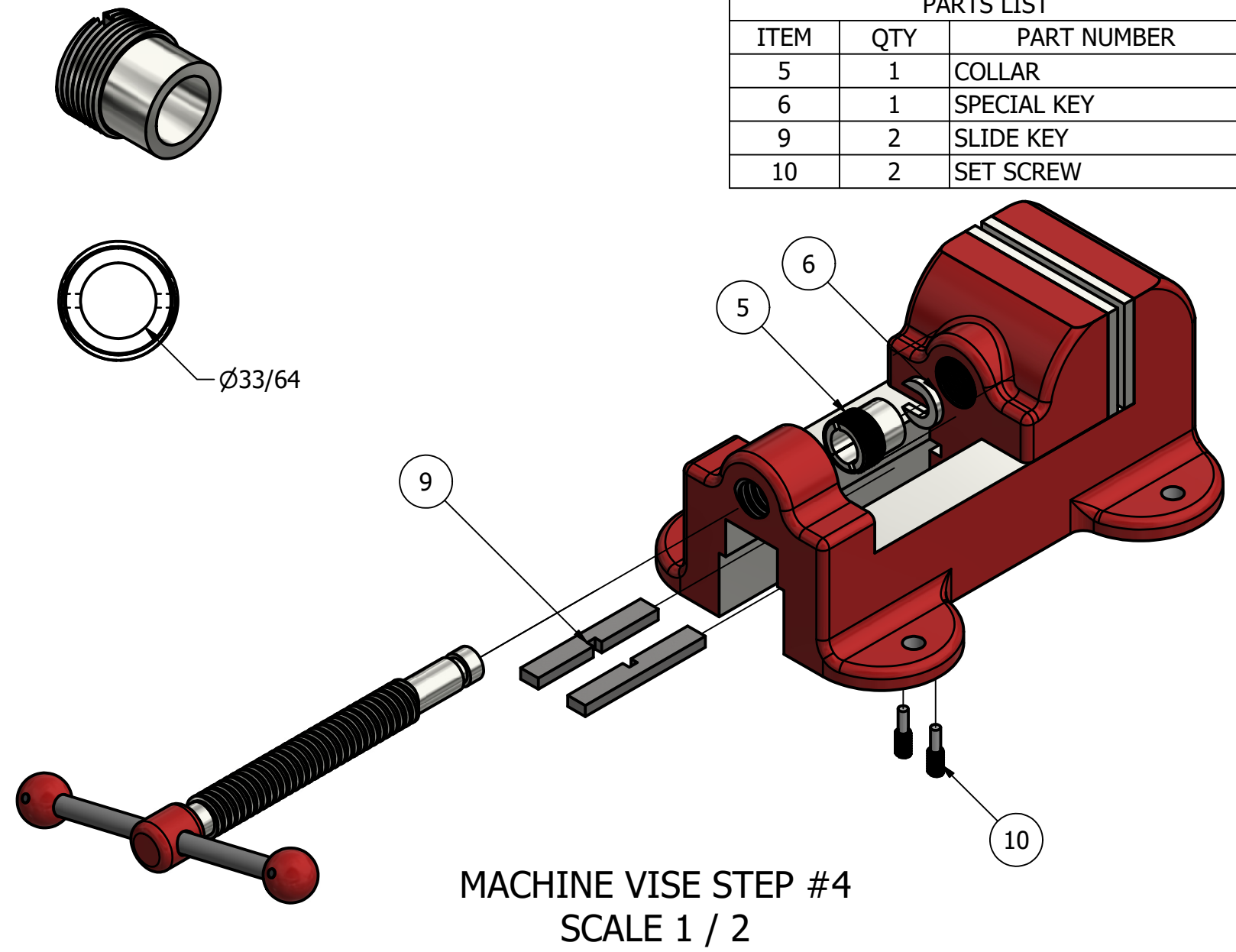
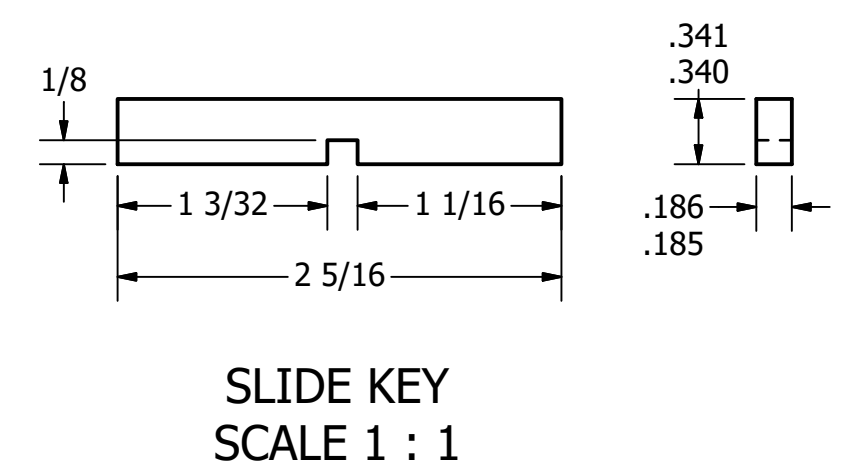
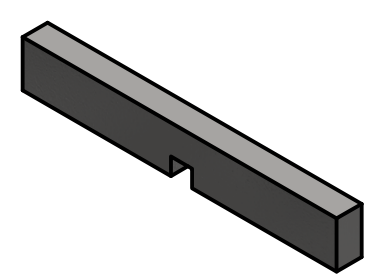
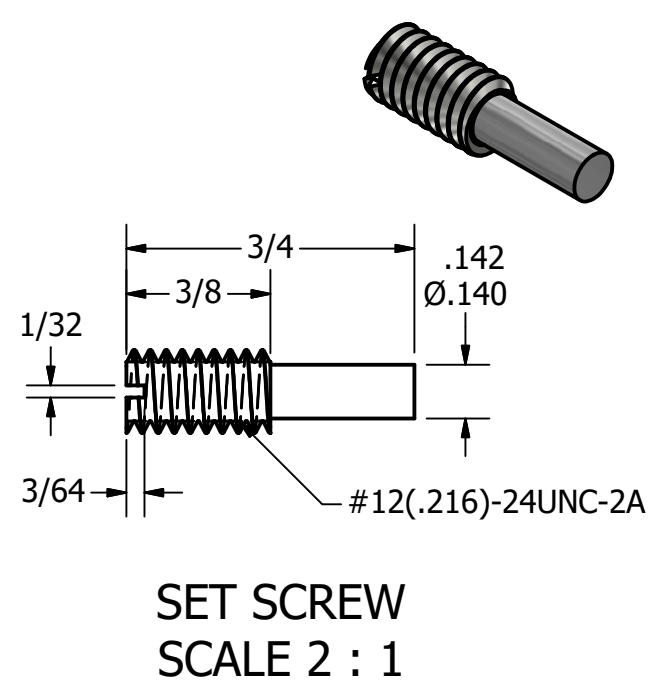
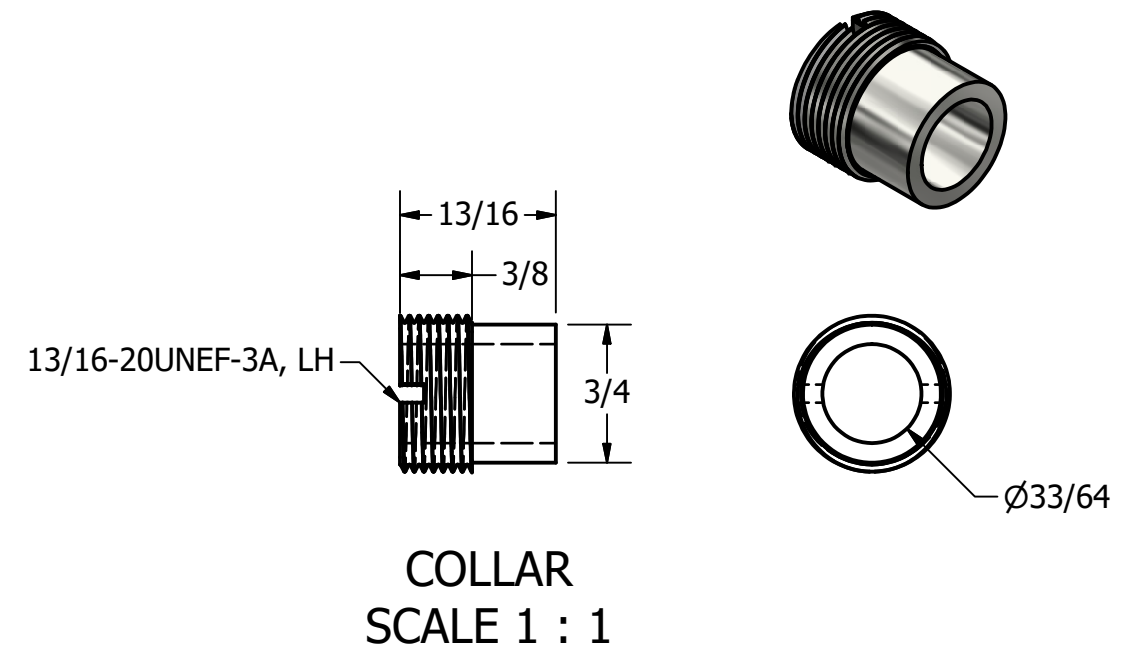
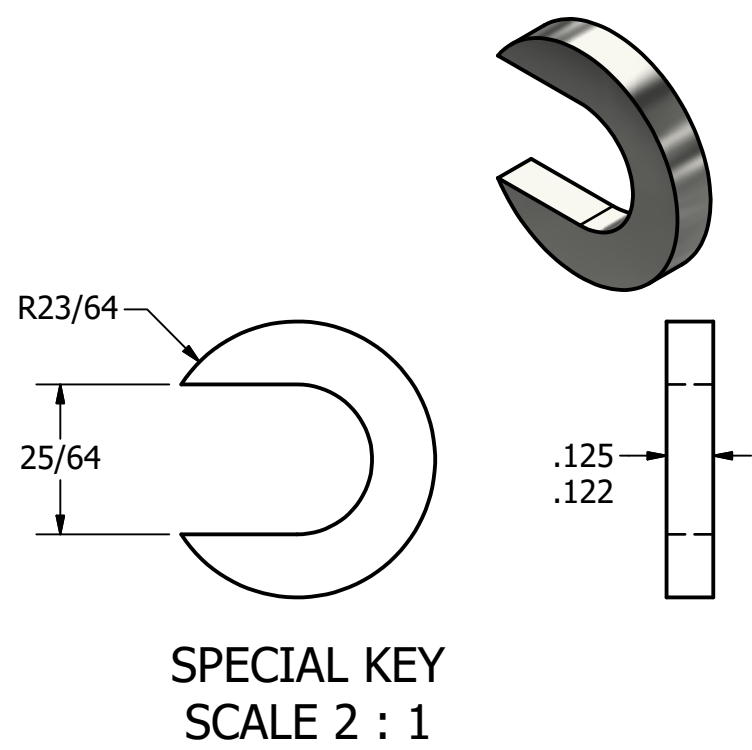

**GENERAL NOTES:**  
FILLEDS AND ROUNDS R.125 UNLESS OTHERWISE NOTED

- LEGEND:**
- Ø DIAMETER
  - R RADIUS
  - ° DEGRES
  - COUNTERBORE
  - ▽ DEPTH
  - ∨ COUNTERSINK

**DDGT**  
DIGITAL DESIGN  
GRAPHICS  
TECHNOLOGY  
WWW.DDGT.NET

**Fernando Morales**

- Landscape Design
- Retaining Walls
- Decks
- Water Features
- Outdoor Lighting
- Irrigation System
- Top Soil
- Plants, Trees, & Turf
- Stamp Concrete

(707) 304-3362  
morales15fernando@gmail.com  
www.ddgt.net/StudentPages/fmorales

TOLERANCES UNLESS SPECIFIED:  
DECIMAL INCHES:  
X = ±.020  
XX = ±.010  
XXX = ±.005  
FRACTIONAL ±1/64"  
ANGLES ±1 DEGREE  
SURFACES 32 ✓

COURSE:	DDGT240
INVENTOR DRAWING NAME:	MACHINE VISE
FIG #:	14-17
DRAFTER:	F. MORALES
DATE:	10/9/2018
SCALE:	AS NOTED
PAGE #:	5 OF 5